



US 20160284772A1

(19) **United States**
(12) **Patent Application Publication**
Chaji et al.

(10) **Pub. No.: US 2016/0284772 A1**
(43) **Pub. Date: Sep. 29, 2016**

(54) **MULTI-FUNCTIONAL ACTIVE MATRIX ORGANIC LIGHT-EMITTING DIODE DISPLAY**

G06F 3/041 (2006.01)
H01L 51/52 (2006.01)

(52) **U.S. Cl.**
CPC *H01L 27/3227* (2013.01); *H01L 27/323* (2013.01); *H01L 51/5246* (2013.01); *H01L 51/5206* (2013.01); *H01L 51/5234* (2013.01); *H01L 51/525* (2013.01); *G06F 3/042* (2013.01); *G06F 3/0412* (2013.01); *H01L 2251/5323* (2013.01); *H01L 2251/308* (2013.01); *H01L 2251/558* (2013.01); *H01L 2251/305* (2013.01); *H01L 2251/301* (2013.01); *H01L 51/5056* (2013.01)

(71) Applicant: **Ignis Innovation Inc.**, Waterloo (CA)

(72) Inventors: **Gholamreza Chaji**, Waterloo (CA);
Baolin Tian, Kitchener (CA)

(21) Appl. No.: **15/174,174**

(22) Filed: **Jun. 6, 2016**

Related U.S. Application Data

(63) Continuation of application No. 13/689,241, filed on Nov. 29, 2012, now Pat. No. 9,385,169.

(60) Provisional application No. 61/564,634, filed on Nov. 29, 2011.

Publication Classification

(51) **Int. Cl.**
H01L 27/32 (2006.01)
G06F 3/042 (2006.01)

(57) **ABSTRACT**

A multi-functional active matrix display comprises a transparent front sheet, a semi-transparent layer of light emissive devices adjacent the rear side of the front sheet and forming a matrix of display pixels, and a solar cell layer located behind the light emissive devices for converting both ambient light and internal light from the light emissive devices into electrical energy, the solar cell layer including an array of electrodes on the front surface of the solar cell layer for use in detecting the location of a change in the amount of light impinging on a portion of the front surface of the solar cell layer.

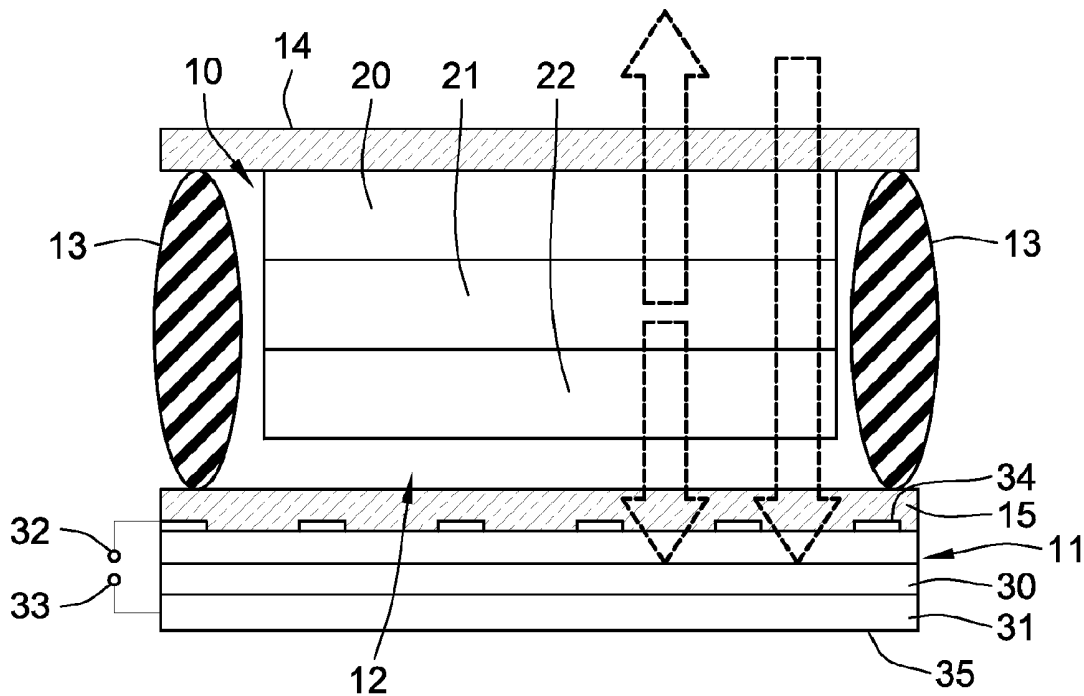

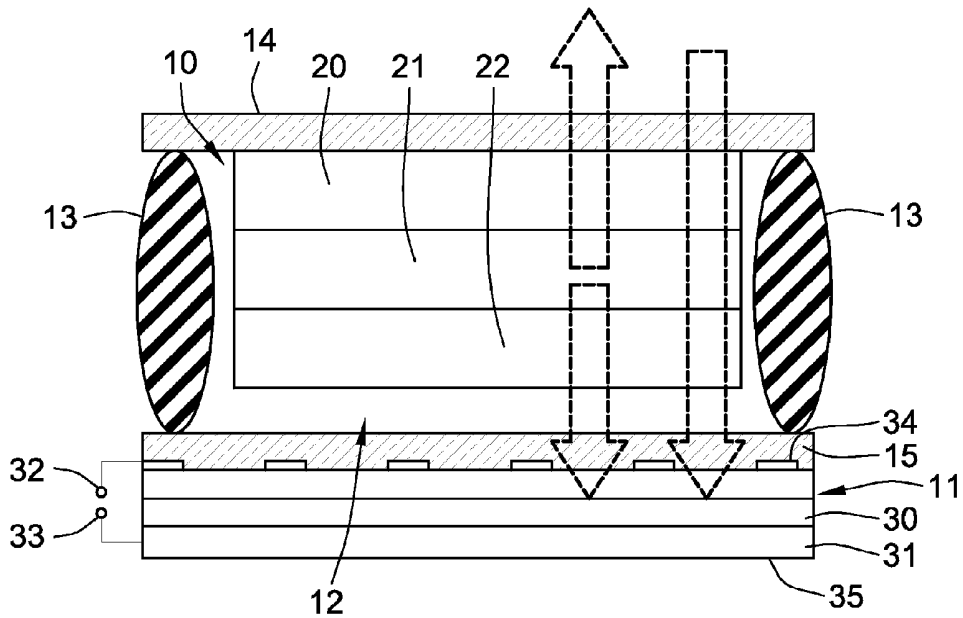

FIG. 1

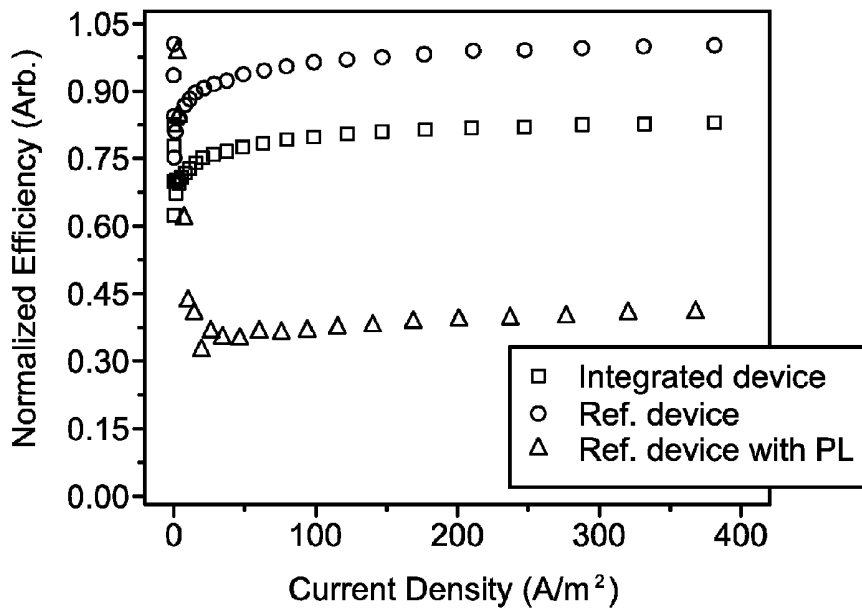

FIG. 2

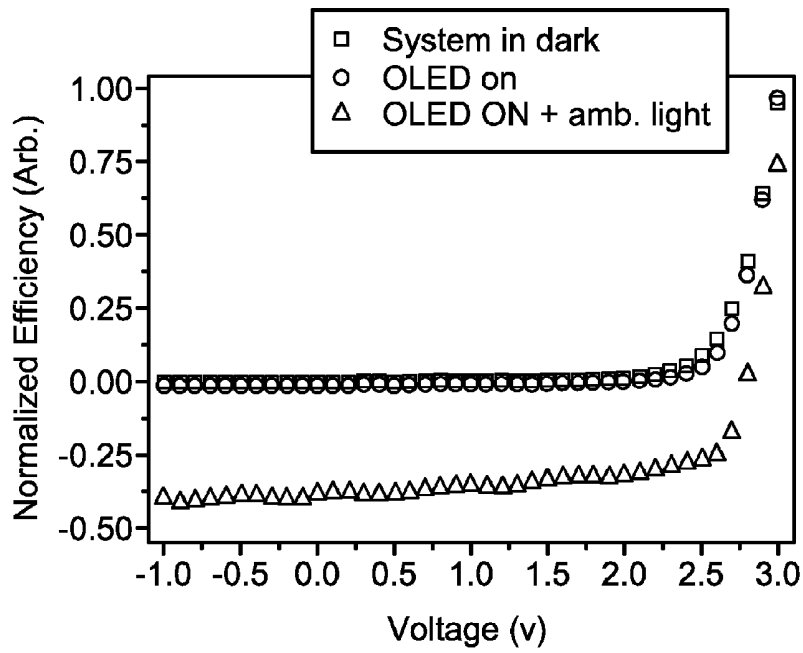

FIG. 3

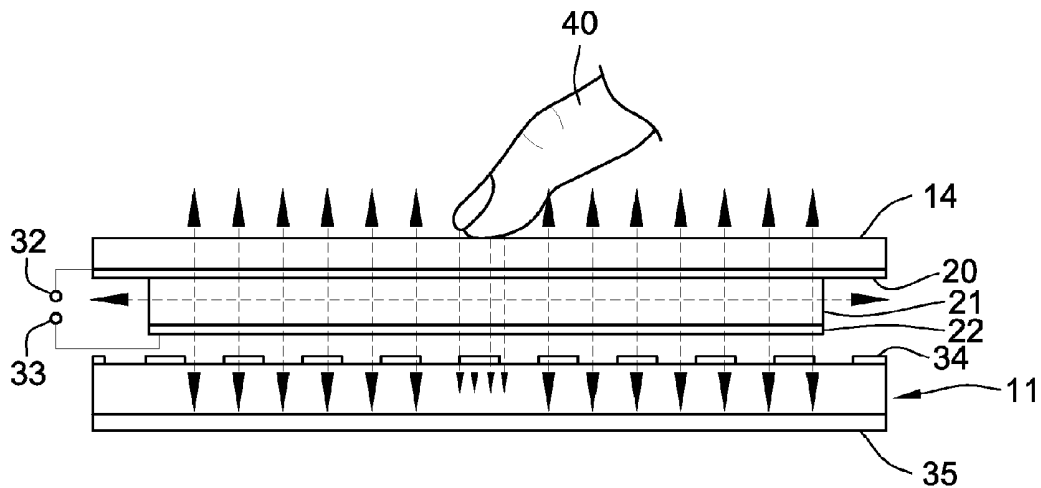

FIG. 4

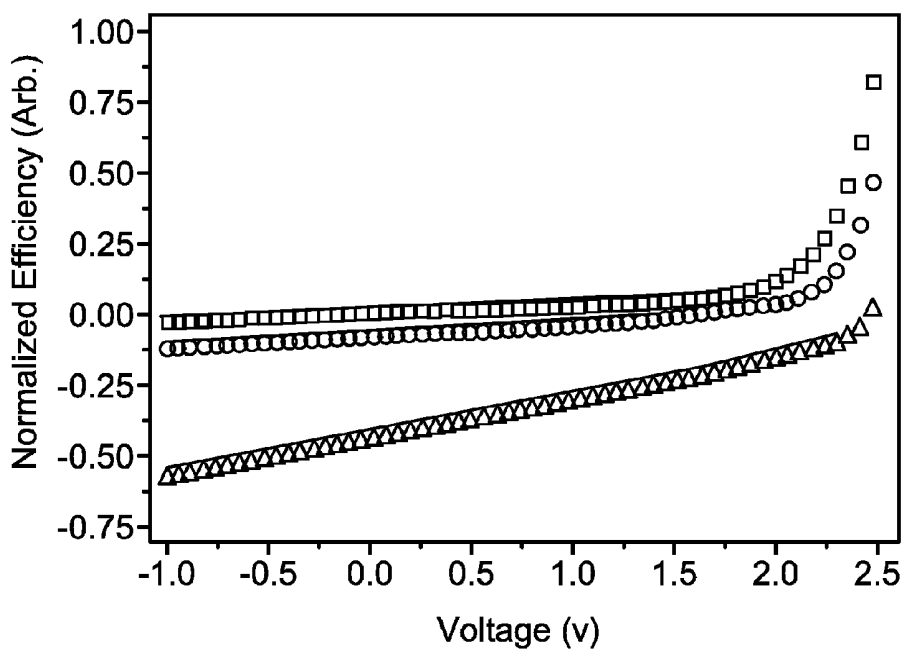

FIG. 5

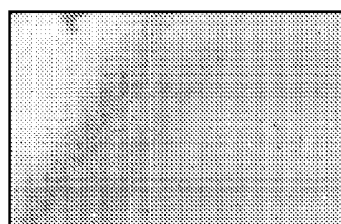

FIG. 6A

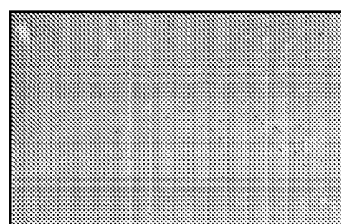

FIG. 6B

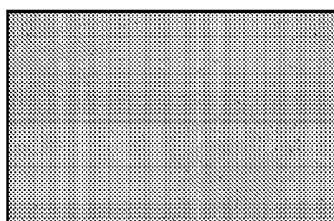

FIG. 6C

**MULTI-FUNCTIONAL ACTIVE MATRIX
ORGANIC LIGHT-EMITTING DIODE
DISPLAY**

**CROSS REFERENCE TO RELATED
APPLICATION**

[0001] This application claims priority to U.S. Provisional Application No. 61/564,634 filed Nov. 29, 2011, the contents of which are hereby incorporated by reference herein in their entirety.

FIELD OF THE INVENTION

[0002] The present invention relates generally to active matrix displays organic light-emitting diode (AMOLED) displays and, more particularly, to multi-functional AMOLED displays having integrated solar cells.

BACKGROUND OF THE INVENTION

[0003] Organic light-emitting diodes (OLEDs) have attracted significant attention because of their great potential for making next-generation flat panel displays, i.e., active-matrix organic light-emitting diode displays (AMOLEDs). The standard OLEDs consist of a transparent electrode, organic layers and a metallic reflective electrode, which experience a strong ambient light reflection and a reduced contrast of displays operating under sunlight, mandating a circular polarizer. Other approaches, such as black cathodes, have been proposed. However, all these designs absorb and waste the incident ambient light and a significant amount of light emitted by the OLEDs. In addition, AMOLEDs today are typically integrated with a touch panel in front of the AMOLED in many applications such as cellular phones, personal digital assistants (PDAs), computer displays and touch tablets. The light output from the OLEDs is further reduced by the touch panel. Altogether, the AMOLED display system is complex and costly, and exhibits relatively low efficiency and wastes a large amount of energy.

SUMMARY OF THE INVENTION

[0004] In accordance with one embodiment, a multi-functional active matrix display comprises a transparent front sheet, a semi-transparent layer of light emissive devices adjacent the rear side of the front sheet and forming a matrix of display pixels, and a solar cell layer located behind the light emissive devices for converting both ambient light and internal light from the light emissive devices into electrical energy, the solar cell layer including an array of electrodes on the front surface of the solar cell layer for use in detecting the location of a change in the amount of light impinging on a portion of the front surface of the solar cell layer.

[0005] In one implementation, the semi-transparent layer of light emissive devices includes a substantially transparent anode adjacent the transparent front sheet, a semi-transparent semiconductor stack forming organic light emitting diodes adjacent the rear side of the anode, and a semi-transparent cathode adjacent the rear side of the semiconductor stack. A cover glass is spaced rearwardly of the cathode, covering the solar cell layer, and a peripheral sealant bonds the cover glass to the front sheet. The peripheral sealant holds the cover sheet spaced away from the rear side of said cathode to form an air gap between the cathode and said the sheet.

[0006] This integration of the semi-transparent OLED panel and the solar panel offers ease of fabrication and low

cost while providing advantages of multi-functionality such as low ambient light reflection, low power consumption, high yield and optical touch screen functionality. Specifically, the integrated device permits the touching of portions of the front surface of an active matrix OLED display to be sensed by using the solar panel to produce an electrical output signal corresponding to light that passes through said OLED display, including light reflected from an object touching the front surface of said OLED display. Then the location of the touching object can be determined by monitoring and analyzing the electrical output signals produced by said solar panel, using conventional touch-screen circuitry.

[0007] With this design, the incident ambient light and the portion of light emitted through the transparent electrode is absorbed by the back solar cell instead of being reflected, resulting in improved contrast in the displayed image. Moreover, in contrast with the polarizer and black cathode approaches, the absorbed light is recycled as useful electrical power or touch feedback instead of being converted to heat. At the same time, the display system can be manufactured with high yields by using independent panel and solar cell processes. Since the polarizer used in AMOLED displays typically has only about 43% transmittance, displays lose 57% of their electroluminescence by using the polarizer.

[0008] Using the display system itself as an optical-based touch screen, without extra IR-LEDs and sensors, reduces the device complexity and fabrication cost of the display system by eliminating the need for extra IR-LEDs and sensors. The solar cell can also be used for initial uniformity calibration of the display, e.g., for correcting non-uniformities of an active matrix OLED display by (a) integrating the OLED display with a solar panel that produces an electrical output signal corresponding to light emissions from the OLED display, (b) detecting non-uniformities in the OLED display from said output signal, and (c) correcting the detected non-uniformities in the OLED display.

[0009] This display system has a simple structure that exhibits superior contrast without sacrificing electroluminescence, a high power efficiency by recycling OLED internal emissions as well as incident ambient light, and touch screen functionality.

BRIEF DESCRIPTION OF THE DRAWINGS

[0010] The foregoing and other advantages of the present disclosure will become apparent upon reading the following detailed description and upon reference to the drawings.

[0011] FIG. 1 is diagrammatic side elevation of an active matrix display that includes integrated solar cell and semi-transparent OLED layers.

[0012] FIG. 2 is a plot of current efficiency vs. current density for the integrated device of FIG. 1 and a reference device.

[0013] FIG. 3 is a plot of current efficiency vs. voltage for the integrated device of FIG. 1 with the solar cell in a dark environment, under illumination of the OLED layer, and under illumination of both the OLED layer and ambient light.

[0014] FIG. 4 is a diagrammatic illustration of the integrated device of FIG. 1 operating as an optical-based touch screen.

[0015] FIG. 5 is a plot of current efficiency vs. voltage for the integrated device of FIG. 1 with the solar cell in a dark environment, under illumination of the OLED layer with and without touch.

[0016] FIG. 6A is an image of an AMOLED panel without compensation.

[0017] FIG. 6B is an image of an AMOLED panel with in-pixel compensation.

[0018] FIG. 6C is an image of an AMOLED panel with extra external calibration.

DETAILED DESCRIPTION OF THE ILLUSTRATED EMBODIMENTS

[0019] Although the invention will be described in connection with certain aspects and/or embodiments, it will be understood that the invention is not limited to those particular aspects and/or embodiments. On the contrary, the invention is intended to cover all alternatives, modifications, and equivalent arrangements as may be included within the spirit and scope of the invention as defined by the appended claims.

[0020] FIG. 1 illustrates a display system that includes a semi-transparent OLED layer 10 integrated with a solar panel 11 separated from the OLED layer 10 by an air gap 12. The OLED layer 10 includes multiple pixels arranged in an X-Y matrix that is combined with programming, driving and control lines connected to the different rows and columns of the pixels. A peripheral sealant 13 (e.g., epoxy) holds the two layers 10 and 11 in the desired positions relative to each other. The OLED layer 10 has a glass substrate 14, the solar panel 11 has a glass cover 15, and the sealant 13 is bonded to the opposed surfaces of the substrate 14 and the cover 15 to form an integrated structure.

[0021] The OLED layer 10 includes a substantially transparent anode 20, e.g., indium-tin-oxide (ITO), adjacent the glass substrate 14, an organic semiconductor stack 21 engaging the rear surface of the anode 20, and a cathode 22 engaging the rear surface of the stack 21. The cathode 22 is made of a transparent or semi-transparent material, e.g., thin silver (Ag), to allow light to pass through the OLED layer 10 to the solar panel 11. (The anode 20 and the semiconductor stack 21 in OLEDs are typically at least semi-transparent, but the cathode in previous OLEDs has often been opaque and sometimes even light-absorbing to minimize the reflection of ambient light from the OLED.)

[0022] Light that passes rearwardly through the OLED layer 10, as illustrated by the right-hand arrow in FIG. 1, continues on through the air gap 12 and the cover glass cover 15 of the solar cell 11 to the junction between n-type and p-type semiconductor layers 30 and 31 in the solar cell. Optical energy passing through the glass cover 15 is converted to electrical energy by the semiconductor layers 30 and 31, producing an output voltage across a pair of output terminals 32 and 33. The various materials that can be used in the layers 30 and 31 to convert light to electrical energy, as well as the material dimensions, are well known in the solar cell industry. The positive output terminal 32 is connected to the n-type semiconductor layer 30 (e.g., copper phthalocyanine) by front electrodes 34 attached to the front surface of the layer 30. The negative output terminal 33 is connected to the p-type semiconductor layer 31 (e.g., 3, 4, 9, 10-perylenetetracarboxylic bis-benzimidazole) by rear electrodes 35 attached to the rear surface of the layer 31.

[0023] One or more switches may be connected to the terminals 32 and 33 to permit the solar panel 11 to be controllably connected to either (1) an electrical energy storage device such as a rechargeable battery or one or more capaci-

tors, or (2) to a system that uses the solar panel 11 as a touch screen, to detect when and where the front of the display is "touched" by a user.

[0024] In the illustrative embodiment of FIG. 1, the solar panel 11 is used to form part of the encapsulation of the OLED layer 10 by forming the rear wall of the encapsulation for the entire display. Specifically, the cover glass 15 of the solar cell array forms the rear wall of the encapsulation for the OLED layer 10, the single glass substrate 14 forms the front wall, and the perimeter sealant 13 forms the side walls.

[0025] One example of a suitable semitransparent OLED layer 10 includes the following materials:

Anode 20

[0026] ITO (100 nm)

Semiconductor Stack 21

[0027] hole transport layer—N,N'-bis(naphthalen-1-yl)-N,N'-bis(phenyl)benzidine (NBP) (70 nm)

[0028] emitter layer—tris(8-hydroxyquinoline) aluminum (Alq₃): 10-(2-benzothiazolyl)-1,1,7,7-tetramethyl-2,3,6,7-tetrahydro-1H, 5H, 11H, [1] benzo-pyrano [6,7,8-ij]quinolizin-11-one (C545T) (99%:1%) (30 nm)

[0029] electron transport layer—Alq₃ (40 nm)

[0030] electron injection layer—4,7-diphenyl-1,10-phenanthroline (Bphen): (Cs₂CO₃) (9:1) (10 nm)

Semitransparent Cathode 22—

[0031] MoO₃:NPB(1:1) (20 nm)

[0032] Ag (14 nm)

[0033] MoO₃:NPB(1:1) (20 nm)

[0034] The performance of the above OLED layer in an integrated device using a commercial solar panel was compared with a reference device, which was an OLED with exactly the same semiconductor stack and a metallic cathode (Mg/Ag). The reflectance of the reference device was very high, due to the reflection of the metallic electrode; in contrast, the reflectance of the integrated device is very low. The reflectance of the integrated device with the transparent electrode was much lower than the reflectances of both the reference device (with the metallic electrode) and the reference device equipped with a circular polarizer.

[0035] The current efficiency-current density characteristics of the integrated device with the transparent electrode and the reference device are shown in FIG. 2. At a current density of 200 A/m², the integrated device with the transparent electrode had a current efficiency of 5.88 cd/A, which was 82.8% of the current efficiency (7.1 cd/A) of the reference device. The current efficiency of the reference device with a circular polarizer was only 60% of the current efficiency of the reference device. The integrated device converts both the incident ambient light and a portion of the OLED internal luminance into useful electrical energy instead of being wasted.

[0036] For both the integrated device and the reference device described above, all materials were deposited sequentially at a rate of 1-3 Å/s using vacuum thermal evaporation at a pressure below 5×10⁻⁶ Torr on ITO-coated glass substrates. The substrates were cleaned with acetone and isopropyl alcohol, dried in an oven, and finally cleaned by UV ozone treatment before use. In the integrated device, the solar panel was a commercial Sanyo Energy AM-1456CA amorphous silicon solar cell with a short circuit current of 6 μA and a voltage

output of 2.4V. The integrated device was fabricated using the custom cut solar cell as encapsulation glass for the OLED layer.

[0037] The optical reflectance of the device was measured by using a Shimadzu UV-2501PC UV-Visible spectrophotometer. The current density (J)-luminance (L)-voltage (V) characteristics of the device was measured with an Agilent 4155C semiconductor parameter analyzer and a silicon photodiode pre-calibrated by a Minolta Chromameter. The ambient light was room light, and the tests were carried out at room temperature. The performances of the fabricated devices were compared with each other and with the reference device equipped with a circular polarizer.

[0038] FIG. 3 shows current-voltage (I-V) characteristics of the solar panel (1) in dark, (2) under the illumination of OLED, and (3) under illumination of both ambient light and the OLED at 20 mA/cm². The dark current of the solar cell shows a nice diode characteristic. When the solar cell is under the illumination of the OLED under 20 mA/cm² current density, the solar cell shows a short circuit current (I_{sc}) of $-0.16 \mu\text{A}$, an open circuit voltage (V_{oc}) of 1.6V, and a filling factor (FF) of 0.31. The maximum converted electrical power is 0.08 μW , which demonstrates that the integrated device is capable of recycling a portion of the internal OLED luminance energy. When the solar cell is under the illumination of both ambient light and the overlying OLED, the solar cell shows a short circuit current (I_{sc}) of $-7.63 \mu\text{A}$, an open circuit voltage (V_{oc}) of 2.79V, and a filling factor (FF) of 0.65. The maximum converted electrical power is 13.8 μW in this case. The increased electrical power comes from the incident ambient light.

[0039] Overall, the integrated device shows a higher current efficiency than the reference device with a circular polarizer, and further recycles the energy of the incident ambient light and the internal luminance of the top OLED, which demonstrates a significant low power consumption display system.

[0040] Conventional touch displays stack a touch panel on top of an LCD or AMOLED display. The touch panel reduces the luminance output of the display beneath the touch panel and adds extra cost to the fabrication. The integrated device described above is capable of functioning as an optical-based touch screen without any extra panels or cost. Unlike previous optical-based touch screens which require extra IR-LEDs and sensors, the integrated device described here utilizes the internal illumination from the top OLED as an optical signal, and the solar cell is utilized as an optical sensor. Since the OLED has very good luminance uniformity, the emitted light is evenly spread across the device surface as well as the surface of the solar panel. When the front surface of the display is touched by a finger or other object, a portion of the emitted light is reflected off the object back into the device and onto the solar panel, which changes the electrical output of the solar panel. The system is able to detect this change in the electrical output, thereby detecting the touch. The benefit of this optical-based touch system is that it works for any object (dry finger, wet finger, gloved finger, stylus, pen, etc.), because detection of the touch is based on the optical reflection rather than a change in the refractive index, capacitance or resistance of the touch panel.

[0041] FIG. 4 is a diagrammatic illustration of the integrated device of FIG. 1 being used as a touch screen. To allow the solar cell to convert a significant amount of light that impinges on the front of the cell, the front electrodes 34 are

spaced apart to leave a large amount of open area through which impinging light can pass to the front semiconductor layer 30. The illustrative electrode pattern in FIG. 4 has all the front electrodes 34 extending in the X direction, and all the back contacts 35 extending in the Y direction. Alternatively, one electrode can be patterned in both directions. An additional option is the addition of tall wall traces covered with metal so that they can be connected to the OLED transparent electrode to further reduce the resistance. Another option is to fill the gap 12 between the OLED layer 10 and the cover glass 15 with a transparent material that acts as an optical glue, for better light transmittance.

[0042] When the front of the display is touched or obstructed by a finger 40 (FIG. 4) or other object that reflects or otherwise changes the amount of light impinging on the solar panel at a particular location, the resulting change in the electrical output of the solar panel can be detected. The electrodes 34 and 35 are all individually connected to a touch screen controller circuit that monitors the current levels in the individual electrodes, and/or the voltage levels across different pairs of electrodes, and analyzes the location responsible for each change in those current and/or voltage levels. Touch screen controller circuits are well known in the touch-screen industry, and are capable of quickly and accurately reading the exact position of a "touch" that causes a change in the electrode currents and/or voltages being monitored. The touch screen circuits may be active whenever the display is active, or a proximity switch can be used to activate the touch screen circuits only when the front surface of the display is touched.

[0043] The solar panel may also be used for imaging, as well as a touch screen. An algorithm may be used to capture multiple images, using different pixels of the display to provide different levels of brightness for compressive sensing.

[0044] FIG. 5 is a plot of normalized current I_{sc} vs. voltage V_{oc} characteristics of the solar panel under the illumination of the overlying OLED layer, with and without touch. When the front of the integrated device is touched, I_{sc} and V_{oc} of the solar cell change from $-0.16 \mu\text{A}$ to $-0.87 \mu\text{A}$ and 1.6 V to 2.46 V, respectively, which allows the system to detect the touch. Since this technology is based on the contrast between the illuminating background and the light reflected by a fingertip, for example, the ambient light has an influence on the touch sensitivity of the system. The changes in I_{sc} or V_{oc} in FIG. 5 are relatively small, but by improving the solar cell efficiency and controlling the amount of background luminance by changing the thickness of the semitransparent cathode of the OLED, the contrast can be further improved. In general, a thinner semitransparent OLED cathode will benefit the luminance efficiency and lower the ambient light reflectance; however, it has a negative influence on the contrast of the touch screen.

[0045] In a modified embodiment, the solar panel is calibrated with different OLED and/or ambient brightness levels, and the values are stored in a lookup table (LUT). Touching the surface of the display changes the optical behavior of the stacked structure, and an expected value for each cell can be fetched from the LUT based on the OLED luminance and the ambient light. The output voltage or current from the solar cells can then be read, and a profile created based on differences between expected values and measured values. A predefined library or dictionary can be used to translate the created profile to different gestures or touch functions.

[0046] In another modified embodiment, each solar cell unit represents a pixel or sub-pixel, and the solar cells are calibrated as smaller units (pixel resolution) with light sources at different colors. Each solar cell unit may represent a cluster of pixels or sub-pixels. The solar cells are calibrated as smaller units (pixel resolution) with reference light sources at different color and brightness levels, and the values stored in LUTs or used to make functions. The calibration measurements can be repeated during the display lifetime by the user or at defined intervals based on the usage of the display. Calibrating the input video signals with the values stored in the LUTs can compensate for non-uniformity and aging. Different gray scales may be applied while measuring the values of each solar cell unit, and storing the values in a LUT.

[0047] Each solar cell unit can represent a pixel or sub-pixel. The solar cell can be calibrated as smaller units (pixel resolution) with reference light sources at different colors and brightness levels and the values stored in LUTs or used to make functions. Different gray scales may be applied while measuring the values of each solar cell unit, and then calibrating the input video signals with the values stored in the LUTs to compensate for non-uniformity and aging. The calibration measurements can be repeated during the display lifetime by the user or at defined intervals based on the usage of the display.

[0048] Alternatively, each solar cell unit can represent a pixel or sub-pixel, calibrated as smaller units (pixel resolution) with reference light sources at different colors and brightness levels with the values being stored in LUTs or used to make functions, and then applying different patterns (e.g., created as described in U.S. Patent Application Publication No. 2011/0227964, which is incorporated by reference in its entirety herein) to each cluster and measuring the values of each solar cell unit. The functions and methods described in U.S. Patent Application Publication No. 2011/0227964 may be used to extract the non-uniformities/aging for each pixel in the clusters, with the resulting values being stored in a LUT. The input video signals may then be calibrated with the values stored in LUTs to compensate for non-uniformity and aging. The measurements can be repeated during the display lifetime either by the user or at defined intervals based on display usage.

[0049] The solar panel can also be used for initial uniformity calibration of the display. One of the major problems with OLED panels is non-uniformity. Common sources of non-uniformity are the manufacturing process and differential aging during use. While in-pixel compensation can improve the uniformity of a display, the limited compensation level attainable with this technique is not sufficient for some displays, thereby reducing the yield. With the integrated OLED/solar panel, the output current of the solar panel can be used to detect and correct non-uniformities in the display. Specifically, calibrated imaging can be used to determine the luminance of each pixel at various levels. The theory has also been tested on an AMOLED display, and FIG. 6 shows uniformity images of an AMOLED panel (a) without compensation, (b) with in-pixel compensation and (c) with extra external compensation. FIG. 6(c) highlights the effect of external compensation which increases the yield to a significantly higher level (some ripples are due to the interference between camera and display spatial resolution). Here the solar panel was calibrated with an external source first and then the panel was calibrated with the results extracted from the panel.

[0050] As can be seen from the foregoing description, the integrated display can be used to provide AMOLED displays with a low ambient light reflectance without employing any extra layers (polarizer), low power consumption with recycled electrical energy, and functionality as an optical based touch screen without an extra touch panel, LED sources or sensors. Moreover, the output of the solar panel can be used to detect and correct the non-uniformity of the OLED panel. By carefully choosing the solar cell and adjusting the semi-transparent cathode of the OLED, the performance of this display system can be greatly improved.

[0051] While particular implementations and applications of the present disclosure have been illustrated and described, it is to be understood that the present disclosure is not limited to the precise construction and compositions disclosed herein and that various modifications, changes, and variations can be apparent from the foregoing descriptions without departing from the spirit and scope of the invention as defined in the appended claims.

1-9. (canceled)

10. A method of sensing the touching of portions of the front surface of an active matrix OLED display, the method comprising:

integrating the OLED display with a solar panel located behind said OLED display and producing an electrical output signal corresponding to light that passes through said OLED display, including light emitted by said OLED display and reflected from an object touching the front surface of said OLED display; and

detecting the location of said touching object from said electrical output signal produced by said solar panel.

11. An active matrix display comprising:

a transparent front sheet,

a semi-transparent layer of light emissive devices adjacent the rear side of said front sheet and forming a matrix of display pixels for displaying images for viewing through said front sheet, and

a solar panel located behind said light emissive devices, said solar panel including an array of electrodes on at least one surface of said solar panel for generating output signals for use in detecting the location of a change in the amount of light impinging on a portion of the front surface of said solar panel due to an object in front of said front sheet reflecting light from said emissive devices back through said front sheet and said emissive devices to said solar panel.

12. The active matrix display of claim 11 in which said semi-transparent layer of light emissive devices includes a substantially transparent anode adjacent said front sheet, a semi-transparent semiconductor stack forming organic light emitting diodes adjacent the rear side of said anode, a semi-transparent cathode adjacent the rear side of said semiconductor stack, a cover glass spaced rearwardly of said cathode and covering said solar panel, and a peripheral sealant bonding said cover glass to said transparent front sheet.

13. The active matrix display of claim 12 in which said peripheral sealant holds said cover glass spaced away from the rear side of said cathode to form an air gap between said cathode and said cover glass.

14. The active matrix display of claim 11 in which said transparent front sheet is a glass substrate for said semi-transparent layer of light emissive devices.

15. The active matrix display of claim 11 in which said solar panel includes laminated N-type and P-type semicon-

ductor materials, and said array of electrodes includes multiple electrode segments located on the front surface of said semiconductor laminate and spaced from each other to allow light from said light emissive devices to impinge on said semiconductor laminate.

16. The active matrix display of claim **15** in which said array of electrodes includes first spaced electrode segments running in a first direction on one surface of said semiconductor laminate, and second spaced electrode segments running in a second direction on the opposite surface of said semiconductor laminate.

17. The active matrix display of claim **11** in which said semi-transparent layer of light emissive devices includes a substantially transparent anode and a semi-transparent cathode.

18. The active matrix display of claim **11** further comprising:

a touch screen circuit coupled to said solar panel for receiving said output signals from said array of electrodes and for detecting the location of said change in the amount of light with use of said output signals.

19. An active matrix display system comprising:

a transparent front sheet,

a semi-transparent layer of light emissive devices adjacent the rear side of said front sheet and forming a matrix of display pixels for displaying images for viewing through said front sheet,

a solar panel located behind said light emissive devices for converting light emitted from said light emissive devices into electrical energy, and

electrical energy storage coupled to said solar panel for storing said electrical energy.

20. The active matrix display of claim **19** in which said semi-transparent layer of light emissive devices includes a substantially transparent anode adjacent said front sheet, a semi-transparent semiconductor stack forming organic light emitting diodes adjacent the rear side of said anode, a semi-transparent cathode adjacent the rear side of said semiconductor stack, a cover glass spaced rearwardly of said cathode and covering said solar panel, and a peripheral sealant bonding said cover glass to said transparent front sheet.

21. The active matrix display of claim **20** in which said peripheral sealant holds said cover glass spaced away from the rear side of said cathode to form an air gap between said cathode and said cover glass.

22. The active matrix display of claim **19** in which said transparent front sheet is a glass substrate for said semi-transparent layer of light emissive devices.

23. The active matrix display of claim **19** in which said solar panel includes laminated N-type and P-type semiconductor materials.

24. The active matrix display of claim **19** in which said semi-transparent layer of light emissive devices includes a substantially transparent anode and a semi-transparent cathode.

* * * * *

专利名称(译)	多功能有源矩阵有机发光二极管显示器		
公开(公告)号	US20160284772A1	公开(公告)日	2016-09-29
申请号	US15/174174	申请日	2016-06-06
[标]申请(专利权)人(译)	伊格尼斯创新公司		
申请(专利权)人(译)	IGNIS创新INC.		
当前申请(专利权)人(译)	IGNIS创新INC.		
[标]发明人	CHAJI GHOLAMREZA TIAN BAOLIN		
发明人	CHAJI, GHOLAMREZA TIAN, BAOLIN		
IPC分类号	H01L27/32 G06F3/042 G06F3/041 H01L51/52		
CPC分类号	H01L27/3227 H01L51/0072 H01L51/5246 H01L51/5206 H01L51/5234 H01L51/525 G06F3/042 G06F3/0412 H01L2251/5323 H01L2251/308 H01L2251/558 H01L2251/305 H01L2251/301 H01L51/5056 H01L51/5012 H01L51/5072 H01L51/5092 H01L51/006 H01L51/0058 H01L51/0081 H01L51/0071 H01L27/323 G06F3/0421 G09G3/003 G09G3/3406 G09G2354/00 G09G2358/00 H01L27/288 H01L51/524 H01L51/5284 G09G3/3225		
优先权	61/564634 2011-11-29 US		
其他公开文献	US9818806		
外部链接	Espacenet USPTO		

摘要(译)

一种多功能有源矩阵显示器，包括透明前板，邻近前板后侧的半透明发光装置层，形成显示像素矩阵，以及位于发光装置后面的太阳能电池层。将来自发光装置的环境光和内部光7转换成电能，太阳能电池层包括太阳能电池层前表面上的电极阵列，用于检测照射的光量变化的位置。太阳能电池层的前表面的一部分。

